

Satellites in Next Generation Networks

QoS issues

Stéphane Combes, R&D, Alcatel Space

ITU-T workshop on Satellites in IP
and Multimedia

Geneva, 9-11 December 2002





> What NGN and QoS mean ?

- End-to-end QoS
- Layered model

> Current Satellite Systems

- Access network architectures
- QoS

> Enhancing the current situation

- Expected improvement
- Architectures

> Satellite in NGN

- Status
- Future Activities





- > **NGN (Next Generation Networks) means**
 - Uncoupling services and transport provision (like IN)
 - Multimedia/multi-services/multi-networks
 - Packet-based (IP)
 - QoS and security are *MUST* !

- > **QoS for NGN means**
 - QoS aware network equipment
 - Admission control mechanisms
 - Interaction between call signalling, resources management and admission control



NGN End-to-End QoS

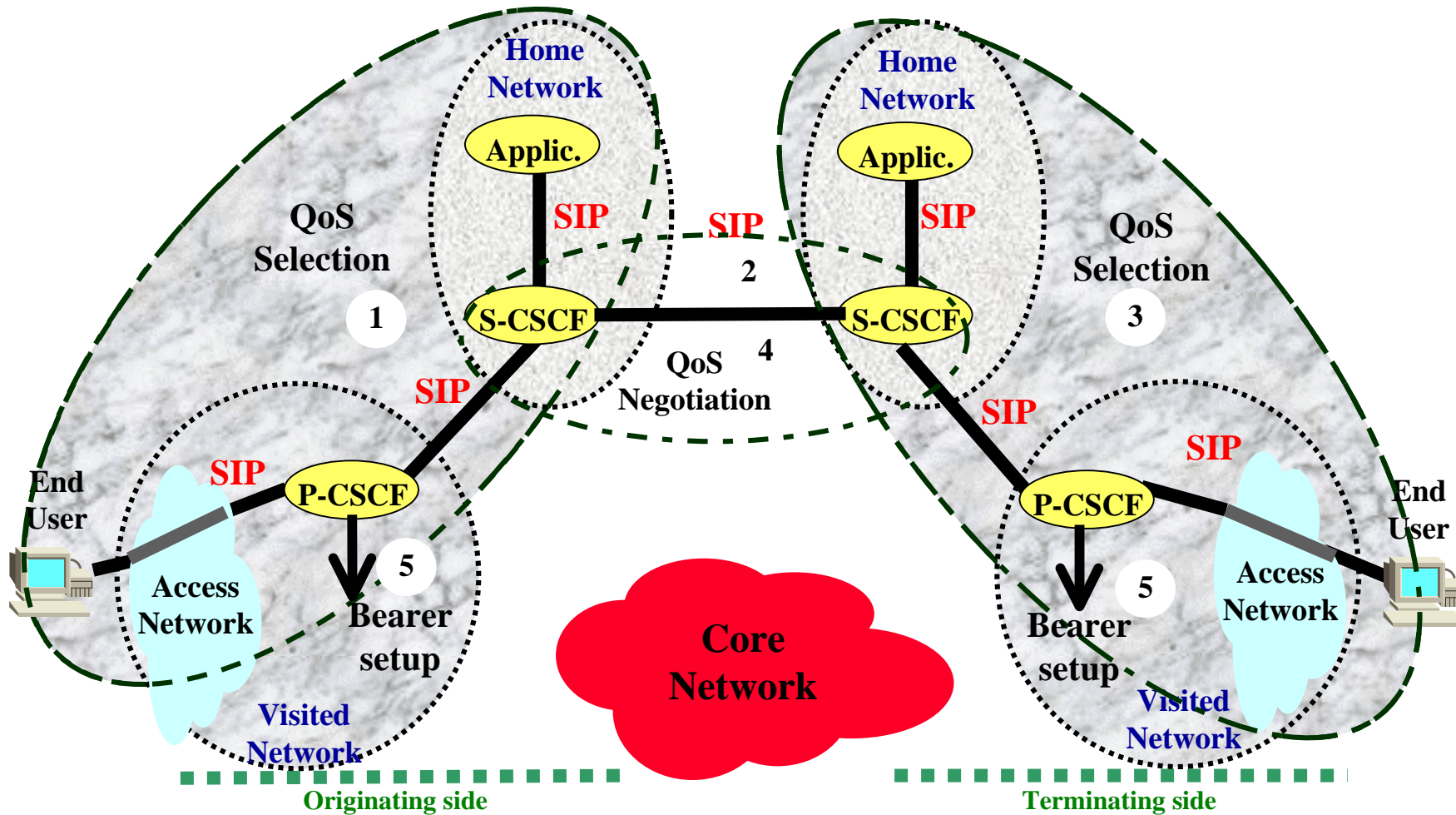

NGN General Layered QoS Model

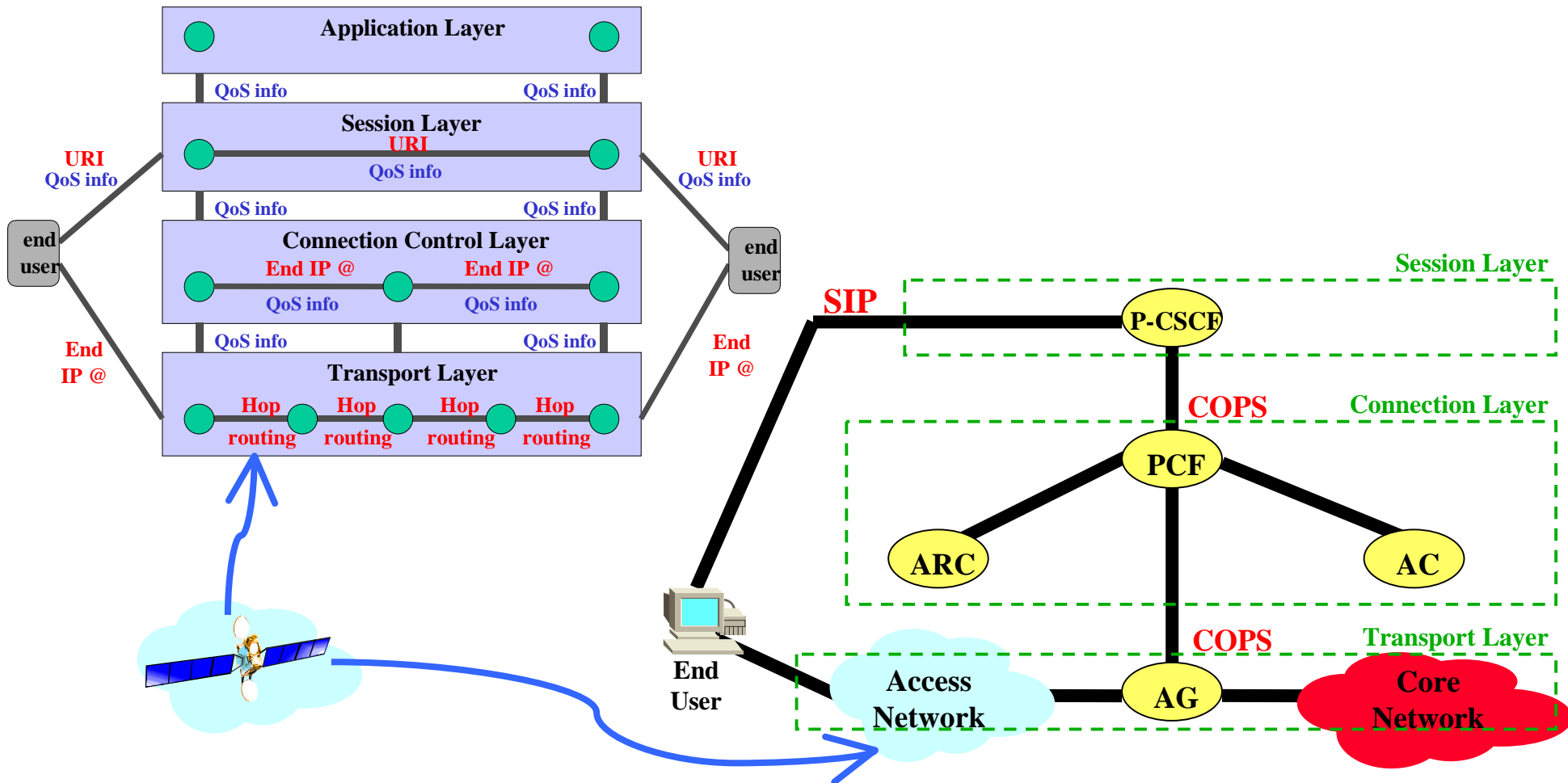

Current Satellite Systems Access Network Architectures

> DVB-RCS architecture

- 2-way multimedia
- IP based
- DVB-S forward link
- MF-TDMA return link
- ATM or MPEG segmentation
- Packet based DAMA

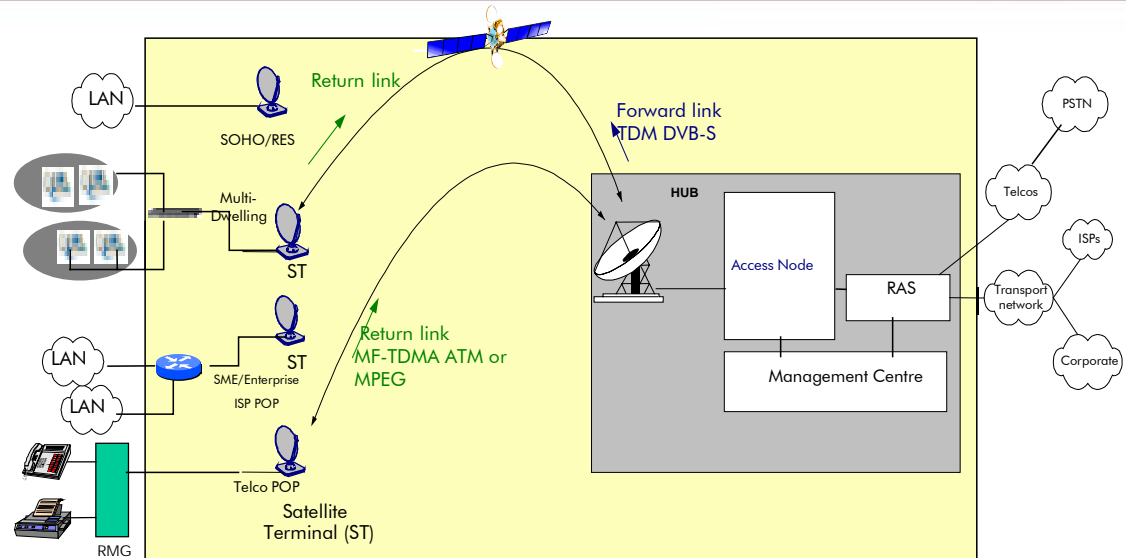

> Regenerative Satellite architecture

- Multi-Gateway
- Mesh: direct ST-to-ST
- ATM or MPEG on-board switching
- DVB-S downlink
- DVB-RCS uplink

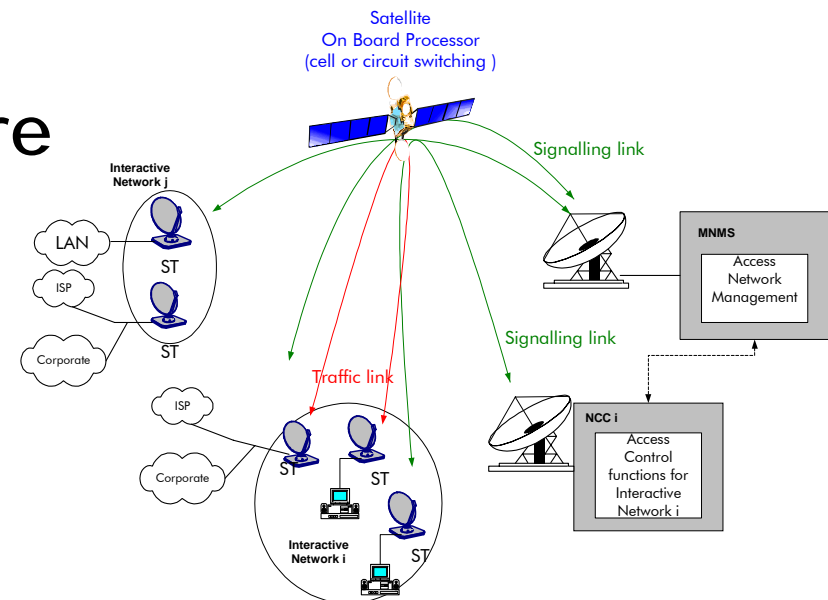

Current Satellite Systems

QoS



> Service Level Agreement (SLA)

- **Satellite network operator** grants a given bandwidth (usually constant) to each service provider for its pool of STs
- **Service providers** grant subscribers a per ST traffic contract:
 - Best effort with peak rate
 - Minimum guaranteed rate with a peak rate

> Static Admission Control

- At ST log-on
- Upon management action

> Traffic Contract Enforcement

- **Return link:** DAMA algorithms using capacity categories defined in DVB-RCS: CRA, RBDC, VBDC, FCA
- **Forward link:** IP and/or ATM traffic management (policy, shaping) in the Hub



Enhancing the current situation

Expected improvements



- > **STEP 1 - Adding flexibility & better QoS in the access**
 - Priority mechanisms between Real-Time and non Real-Time applications according to IP CoS indications (DiffServ DSCP)
 - Coupling between IP and MAC processes in ST
 - Traffic contract modification of the ST from NMC or upon user's request (e.g. using a Web-based interface)

- > **STEP 2 - Interworking between access and core NGN enabled networks**
 - Dynamic admission control based on specific satellite signalling mechanisms
 - Dynamic admission control and resource reservation coupled with call signalling protocols (SIP, H323)



Enhancing the current situation Star Architecture

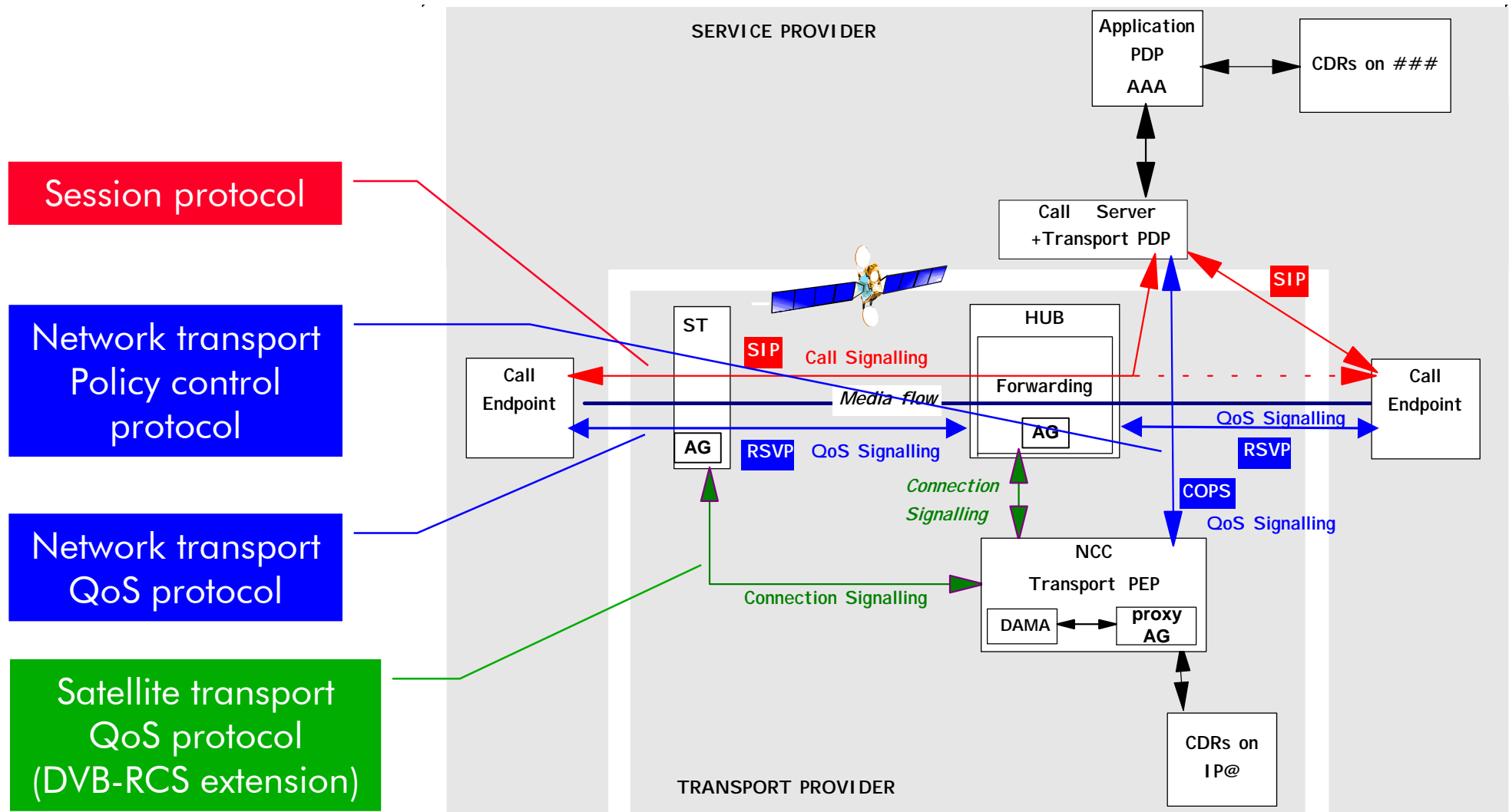

Enhancing the current situation

Mesh architecture

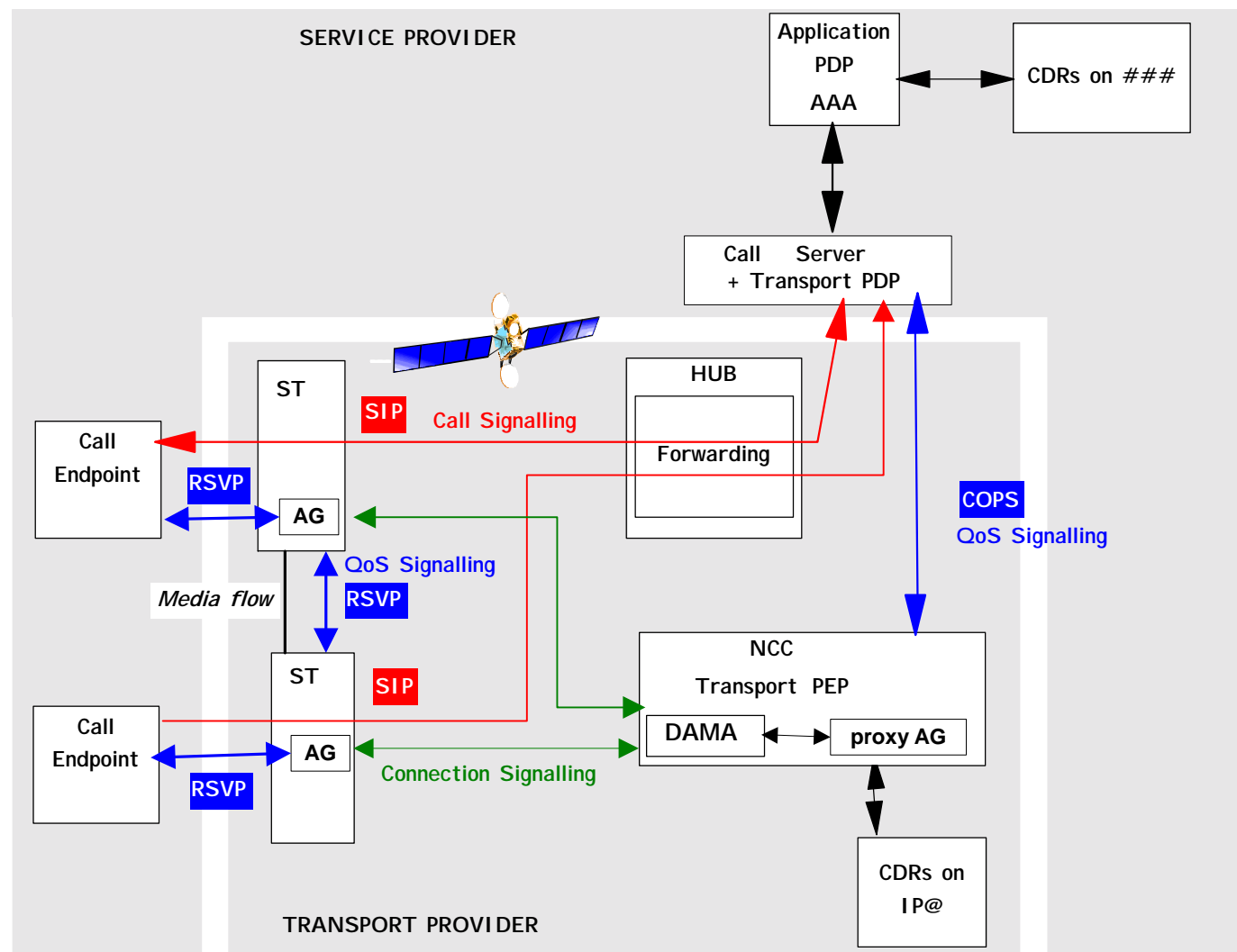

Satellite in NGN Status



- > **Current NGN-related terrestrial network activity is huge**
 - Standards : IETF, ITU, ETSI
 - Planned roll-out for Cable, UMTS and DSL access networks

- > **Satellite system is weak in NGN picture**
 - Only pure physical/access layer standards (DVB-RCS)
 - No QoS support definition
 - No satellite/terrestrial interworking defined
 - Current proprietary solutions and weak QoS
 - May slow down the up-taking of NGN and their associated services through satellite



Satellite in NGN

Future Activities



- > Determine typical **applications/services scenarios** requiring QoS support and their requirements for integration of Broadband Multimedia systems
- > Define **QoS architectures**, identify functional entities and interfaces. Analyse call signalling/resources management/admission control interactions
- > Guarantee **interoperability** with terrestrial NGN protocols or propose extensions/profiles. Analyse specific processing or adaptations required in satellite access equipment at adaptation & access layers
- > Propose potential **extensions or adaptations** to satellite access standards such as DVB-RCS : transparent +OBP based meshed systems



SATIP6 project



- > Funded by EC (IST program)
- > Started march 2002, ends april 2004
- > Partners : Alcatel Space (leader), France Telecom R&D (F), Telecom Italia-Lab (I), SINTEF (N), University of Roma-Sapienza (I), AQL (F), LAAS-CNRS (F)
- > Technical objectives
 - for the short-to-medium term focusing on adaptation of DVB-RCS access for IP services with traditional transparent satellite
 - MPLS based VPN service
 - PPPoE based Internet access
 - for long term in which IPv6 and NGN will be introduced over next generation satellites (regenerative OBP payloads)
 - IPv4/v6 migration
 - NGN QoS
 - multicast optimised security (SatIPSec)
 - IP-Dedicated “connectionless” access over DVB-RCS

